

# specifications

## BB380X-2SW

BackBar X Integral Two Door Chiller  
Type: B2412

### CABINET DIMENSIONS

	External	Internal
<b>Height:</b>	920mm*	758mm
<b>Width:</b>	1500mm	1020mm
<b>Depth:</b>	590mm	530mm
<b>Floor area:</b>	0.89m <sup>2</sup>	

\* Height excludes castors, legs and optional worktop.

#### \*Height variation

Supplied height adjustable castors	1015mm - 1030mm
Supplied height adjustable legs	1050mm - 1080mm
No castors or legs	920mm

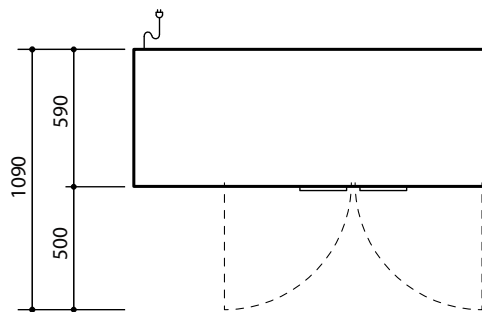

LED horizontal top light

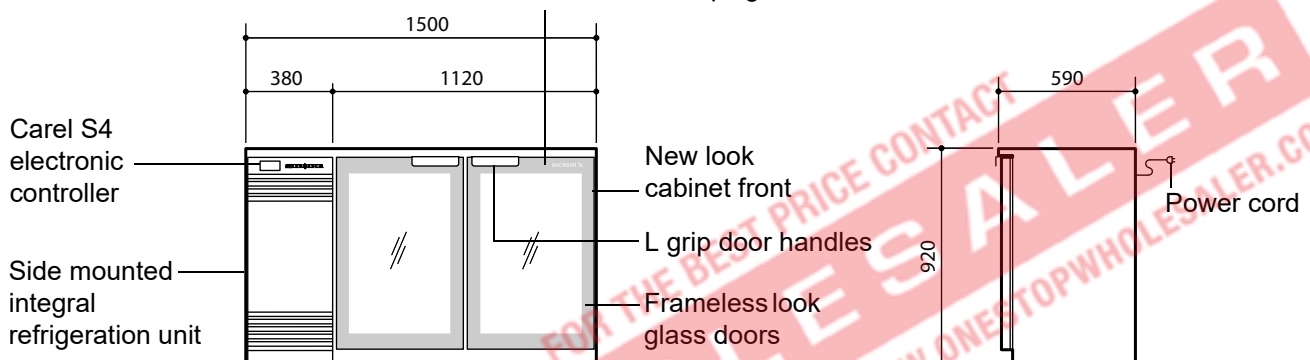

Copyright © 2016 SKOPE Industries Limited

### CABINET SPECIFICATIONS

<b>Refrigeration system:</b>	Electronically controlled, side mounted, integral, removable refrigeration unit (UE30ABF-1001C), with isolation switch
<b>Electronic controller:</b>	Carel S4 Evo
<b>Refrigerant:</b>	R134a / 425g
<b>Nominal capacity:</b>	480 Watts
<b>Cabinet internal volume:</b>	380 litres
<b>Cabinet temperature range:</b>	2°C to 4°C (product mass average)
<b>Climate class:</b>	5
<b>Drainage:</b>	No plumbing required
<b>Electrical:</b>	220-240 Volts a.c. 50 Hz, single phase supply, 3.4 Amps (unit 2.9 Amps)
<b>Internal lighting:</b>	1 x 17W T8 Frosted LED Tube (Ø26 x 900mm, 5500K) - Switched
<b>Internal door opening size:</b>	2 door openings: 720mm high x 470mm wide
<b>Doors:</b>	2 x self-closing, double glazed, toughened, single Low-E safety glass, frameless look doors. Optional door locks.
<b>Worktop (optional):</b>	Optional 25mm stainless steel worktop
<b>Shelves:</b>	Two adjustable height shelves per door: 495mm wide x 440mm deep
<b>Total weight:</b>	150kg

SKOPE Industries Limited reserve the right to alter specifications without notice.

PSS0438 Rev. 2.1 Feb. 2020



**SKOPE INDUSTRIES LIMITED**



New Zealand Freephone: 0800 947 5673, Fax: (03) 983 3896. Australian Freephone: 1800 121 535, Freefax: 1800 121 533

Email: enquiry@skope.co.nz Website: www.skope.co.nz