

# robot coupe®

 **VEGETABLE PREPARATION MACHINE**  
CL 50 • CL 50 Ultra • CL 52



RESTAURANTS – INSTITUTIONS – CATERERS

Efficient, sturdy and easy to clean, these unique models allow a wide variety of cuts.

### Large volume opening



Up to 10 tomatoes or 1/2 cabbage.



### Cylindrical hopper



Ø 58 mm regular slicing of long vegetables such as courgettes, carrots, pepperonis and cucumbers.



**Exactitube pusher:** New  
Ø 39 mm for slicing small-size ingredients such as chillis, gerkins, dry sausage, asparagus, spring onions, bananas, strawberries and grapes.



### Extra large hopper



Up to 15 tomatoes or 1 whole cabbage.



New handle design requires less effort from operator.

## ▶ CL 50 / CL 50 Ultra



50  
400  
Practical output:  
Up to 150 kg/h  
170 mm  
75 mm  
Area: 139 cm<sup>2</sup>

WHOLESALE VISIT: WWW.ONESTOPWHOLESALE.COM  
PHONE: 1300 131 700

550 Watts

## ▶ CL 52



70  
600  
Practical output:  
Up to 250 kg/h  
175 mm  
59 mm  
Area: 227 cm<sup>2</sup>

750 Watts  
Stainless steel  
motor base

## Extra Ergonomic

Designed to process large volumes of vegetables quickly and easily.



**REQUIRES LESS EFFORT  
PREVENTS MSD\*  
TAKES AWAY THE TEDIOUSNESS**



### STURDINESS

Induction motor for intensive use.



### ERGONOMICS

The pusher **automatically** restarts the machine for **easier, quicker** operation.



### SPACE-SAVING

Space-saving lateral ejection.



### EASY CLEANING

New lid shape **eliminating nooks and crannies** where food residue could accumulate.



### SPEED

- 2 versions available:  
1 speed (Single phase or Three phase) 375 rpm.  
2 speeds (Three phase) : 375 rpm and 750 rpm.

\*Musculoskeletal disorders



# Slice, grate, chop, dice, cut fries ...



## ... cut up small-size ingredients ...



## ... and much more:

### ▶ Option: Potato Ricer Attachment

- **Speed and output**

Capable of producing up to 10 kg of fresh and flavoursome mashed potato in just 2 minutes.

- **Ergonomics**

The conveniently wide feed opening allows for the continuous throughput of potatoes – a great labour-saving feature.

- **Versatility**

In addition to the 50 existing ways of processing your fruit and vegetables (slicing, grating, ripple-cutting, dicing, shredding, chipping...) take advantage of the new puréeing attachment of your veg prep machine.



- **Feed tube**  
CL 50/CL 50 Ultra\*



- **Paddle**  
• **Grid : 3 mm or 6 mm**



- **Ejector disc for puréed vegetables**

\*Cannot be used with CL 52





# THE WIDEST VARIETY OF CUTS

## ▶ Slicers



0,6 mm → 10 mm



0,6 mm  
0,8 mm  
1 mm  
2 mm  
3 mm  
4 mm

12 discs

ref.		ref.
28166	5 mm	28065
28069	6 mm	28196
28062	8 mm	28066
28063	10 mm	28067
28064	Cooked potatoes 4 mm	27244
28004	Cooked potatoes 6 mm	27245



## ▶ Ripple-cut



2 mm → 5 mm



3 discs

	ref.
2 mm	27068
3 mm	27069
5 mm	27070



## ▶ Grater



1,5 mm → 9 mm



10 discs

	ref.		ref.
1,5 mm	28056	7 mm	28016
2 mm	28057	9 mm	28060
3 mm	28058	parmesan	28061
4 mm	28073	Radish	28055
5 mm	28059	Röstis potatoes	27164



## ▶ Julienne, Tagliatelles



1x8 mm → 8x8 mm



12 discs

	ref.		ref.
1 x 8 mm	28172	2 x 8 mm (strips)	27067
1 x 26 mm onion/cabbage	28153	2 x 10 mm	28173
2 x 2 mm (celeriac)	28051	3 x 3 mm	28101
2,5 x 2,5 mm	28195	4 x 4 mm	28052
2 x 4 mm (strips)	27072	6 x 6 mm	28053
2 x 6 mm (strips)	27066	8 x 8 mm	28054



## ▶ Dicing



5x5x5 mm → 50x70x25 mm

5 x 5 x 5 mm  
8 x 8 x 8 mm  
10 x 10 x 10 mm  
14 x 14 x 5 mm  
14 x 14 x 10 mm

9 sets

ref.		ref.
28110	14 x 14 x 14 mm	28113
28111	20 x 20 x 20 mm	28114
28112	25 x 25 x 25 mm	28115
28181	50 x 70 x 25 mm	28180
28179		



## ▶ French fries



8x8 mm → 10x16 mm



4 sets

	ref.
8 x 8 mm	28134
8 x 16 mm	28159
10 x 10 mm	28135
10 x 16 mm	28158



# Vegetable Preparation Machine



## The Product Advantages

### Processing capacity :

- **Large hopper** allowing bulky vegetables, such as lettuces and cabbages, to be processed.

### Wide variety of cuts:

- Comprehensive range of **50 discs** for slicing, ripple-cutting, grating and cutting into sticks, strips or dice (from 5x5x5 mm to 50x70x25 mm) with optimum quality and precision every time.
- 375 rpm single-speed appliance ideal for processing delicate foodstuffs, dicing or making french fries, as well as guaranteeing a wide variety of slicing, grating and julienne cuts.
- 375 & 750 rpm two-speed appliance successfully synchronizing speed and cutting precision.

### Simple, sturdy design:

- All parts which come into contact with foodstuffs can easily be removed for cleaning, thus maintaining the highest standards of hygiene.
- Induction motor for intensive use.



## Number of covers:

Up to 600 covers



## Kg Flow rate:

**Practical:** up to 250 kg/hr

**Theoretical:** up to 750 kg/hr



## In brief:

Strong, durable, and easy to clean, you will find no other machines to meet your specific day to day needs so precisely or with such apparent ease and efficiency.

We reserve the right to alter at any time without notice the technical specifications of this appliance. None of the information contained in this document is of a contractual nature. Modifications may be made at any time. © All rights reserved for all countries by :ROBOT-COUCPE s.n.c.



## Induction motor



- **Industrial induction motor for heavy duty use guarantees durability and reliability.**
- Motor built on ball bearings for silent running without vibration
- Direct drive motor:
  - Extra power
  - No complex drive system
- Stainless steel motor shaft



	Electrical data			Weight (kg)	
	Speed (rpm)	Power (Watts)	Voltage* (Amp.)	Net	Gross
CL 50	375	550	230 V/1 - 50 Hz - 5.7	17.6	19.8
CL 50	375	550	400 V/3 - 50 Hz - 1.7	17.6	19.8
CL 50	375 & 750	600	400 V/3 - 50 Hz - 1.8/2.1	17.6	19.8
CL 50 Ultra	375	550	230 V/1 - 50 Hz - 5.7	18	20.2
CL 50 Ultra	375	550	400 V/3 - 50 Hz - 1.7	18	20.2
CL 50 Ultra	375 & 750	600	400 V/3 - 50 Hz - 1.8/2.1	18	20.2
CL 52	375	750	230 V/1 - 50 Hz - 5.3	25.5	28
CL 52	375	750	400 V/3 - 50 Hz - 2.0	25.5	28
CL 52	375 & 750	900	400 V/3 - 50 Hz - 2.7	25,5	28

\* Other voltages available

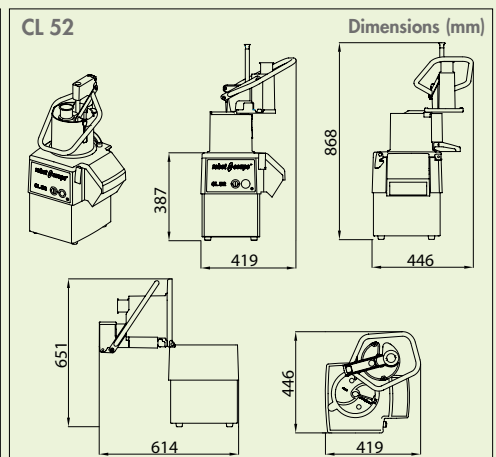
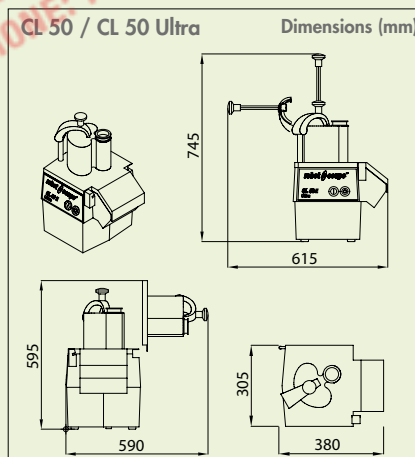

### HEAD OFFICE, FRENCH, EXPORT AND MARKETING DEPARTMENT:

Tel.: + 33 1 43 98 88 33 - Fax: + 33 1 43 74 36 26  
email: international@robot-coupe.com

**Robot Coupe Australia:** Tel.: (02) 9478 0300 - Fax: (02) 9460 7972  
New Zealand: Tel.: 0800 716161 - Fax: 0800 716162  
email: orders@robotcoupe.com.au

**Robot Coupe U.K. LTD:** Tel.: 020 8232 1800 - Fax: 020 8568 4966  
2, Fleming Way, Isleworth, Middlesex TW7 6EU  
email: sales@robotcoupe.co.uk

**Robot Coupe U.S.A.:** Tel.: 1-800-824-1646 - Fax: 601-898-9134  
email: info@robotcoupeusa.com - website: www.robotcoupeusa.com

[www.robot-coupe.com](http://www.robot-coupe.com)

## DISTRIBUTOR

### STANDARDS:

Machines in compliance with:



- The essential requirements of the following European directives and with the corresponding national regulations: 2006/42/CE, 2014/35/UE, 2014/30/UE, 2011/65/UE, 2012/19/UE, CE n° 1935/2004, UE n° 10/2011.

- The requirements of the European harmonized standards and with the standards specifying the hygiene and safety requirements: EN ISO 12100:2010, EN 60204-1:2006, EN 60529: IP 55, IP 34, EN 1678.

Ref. : 451 557 - 10/2019 - Anglais