

robot coupe®



AUTOMATIC SIEVES C80 • C120 • C200



RESTAURANTS - CATERERS - CONFECTIONERS - FISHMONGERS



C 80

- Table-top model.
- Space saving. Easy to move.
- Power 650 W.
- Hourly output : from 40 to 60 kg depending on type of preparation
- Non-stop processing time : 30 minutes maximum



C 120 - C 200 - C 200 V.V.

C 120

- Higher hourly output from 100 to 120 kg depending on type of preparation
- Machine equipped with stainless steel feet
- Available in single or three phase 900 W.

C 200

- Special industry three phase model with 1800 W motor for:
 - intensive use
 - harder products such as blackcurrants processing
- Hourly output : form 120 to 150 kg depending on type of preparation.

C 200 V.V.

- Single phase model with a speed variation from 100 to 150 rpm to obtain an adequate end-texture.



Operating diagram

TRAY
Continious feeding of washed products, no need to stone or peel.



PERFORATED BASKET
Products fall inside the basket where they are sieved.

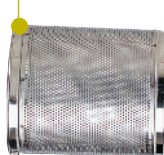

PADDLES
Paddle assembly rotating at 1500 rpm to extract maximum pulp and juice.



END PRODUCT EJECTION CHUTE
The ready to use pulp is ejected here and is free of pips, stones, skin, fibres and bones.

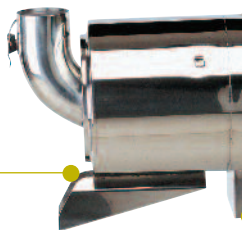

WASTE EJECTION CHUTE
I.E skins, pips, stones, tails, bones, shells, fibres...



AUTOMATIC SIEVES



The Product Benefits:

- Versatility:**

The machine produces juice, fruit purees, vegetable mousses, sauce bases, bisques and fish soups.

- Simple and Sturdy:**

All parts are made of stainless steel to ensure easy cleaning and durability.

Continuous feed hopper for ease of use and time saving.

All parts in contact with food are easily removed and are dishwasher safe



Target:

Restaurants, caterers, confectioners, fishmongers



In brief:

Strain soups, bisques or sauces, extract fruit pulp or separate fibres from vegetables.



Uses/Output	Use	Hourly		End product
		C 80	C120/C200	
FRUITPULPS				
STRAWBERRIES / 90%	Process ripe fruits	60 kg/h	150 kg/h	With the fruitpulp you can make: <ul style="list-style-type: none"> • Icecream • Sorbets • Creams • Fruitpurees • Jams • Fruit-jelly • Jelly
RASPBERRIES / 90%				
BLACKBERRIES / 90%				
REDCURRANTS / 75%	To be blanched for max output	40 kg/h	100 kg/h	
BLACKCURRANTS / 75%				
BILBERRIES / 90%	To be washed before feeding into the machine	60 kg/h	150 kg/h	
TOMATOES / 90%				
MIRABELLE PLUMS / 80%				
CHERRIES / 80%				
PLUMS / 80%				
PEACHES / 80%				
APRICOTS / 80%	Peeled	40 kg/h	100 kg/h	
MELON / 90%				
LEMON / 80%	Use ripe picked grapes	40 kg/h	100 kg/h	
ORANGE / 80%				
GRAPES / 80%				
APPLES / 85%	Grind before processing	40 kg/h	100 kg/h	
COCONUT / 85%				
PINEAPPLE / 90%				
APPLE PUREE / 90%	Cooked	40 kg/h	100 kg/h	
VEGETABLE MOUSSE				
ASPARAGUS / 80%	Thorough cooking before sieving	40 kg/h	100 kg/h	<ul style="list-style-type: none"> • Vegetables purees • Vegetables mousses
CARROTS / 90%				
CELERIAC / 90%				
CUCUMBERS / 95%				
LEEKs / 80%	Cutter grind before processing	40 kg/h	100 kg/h	
BELL PEPPER / 95%				
SOUPS				
FISH / 75%	Grind before processing	60 l/h	*150 l/h and more	<ul style="list-style-type: none"> • Bisque • Cream soups, Soups
SHELLFISH / à 90%				
SAUCES				

RECIPES: Sauce Américaine

Ingredients :

- Shellfish (crustaceans) as desired: live lobster, edible crab • Oil • 50 g butter • 1 clove of garlic
- 12 shallots • 1 carrot • 4 tomatoes • 1 glass of dry white wine • 100 ml fumet (concentrated stock)
- 100 ml cognac • 100 ml Madeira wine • Spices, salt, pepper

Preparation:



- Stun the shellfish and cut them into pieces. Put the coral and the creamy parts to one side. Sauté the pieces of shellfish in oil just until they are well-coloured and then remove them from the frying pan.
- Melt 50 g of butter and allow it to turn a golden colour, then add the garlic, the chopped shallots and the carrot cut into thin round slices. Braise these vegetables, then add the shellfish followed by the tomatoes, white wine, fumet and seasoning.
- Cook for 30 minutes.



- Then add the coral. Stir in the cognac and Madeira wine and cook for another 30 minutes.
- Crush the shells of the shellfish in a cutter-mixer and then slowly pour the preparation into your sieve-juicer. Process to obtain a smooth, creamy sauce.

CE Mark	Electrical data				Dimensions (in mm)			Weight (kg)	
	Speed (rpm)	Power (watts)	Intensity (Amp)	Voltage	A	B	C	Net	Gross
C 80	1500	650	5.7	230 V 50 Hz/1	540	610	360	21 kg	25 kg
	1800	650	12	115 V 60 Hz/1					
C 120	1500	900	230 V - 3.6 400 V - 2.1	230x400 V 50 Hz/3	860	1030	400	40 kg	56 kg
	1500	900	5.5	230 V/50 Hz/1					
	1800	900	12	115 V/60 Hz/1					
C 200	1500	1800	230 V - 7.5 400 V - 4.3	230x400 V 50 Hz/3	860	1030	400	41 kg	57 kg
C 200 V.V.	from 1500 to 1800	1800		230 V 50 Hz/1				53 kg	70 kg

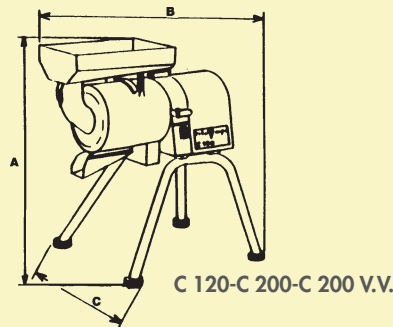
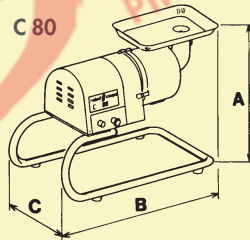

STANDARDS: Machines in compliance with

- The essential requirements of the following European directives and with the corresponding national regulations: 2006/42/EC, 2006/95/EC, 2004/108/EC, 1935/2004/EC, 2002/72/EC, "RoHS" 2002/95/EC, "WEEE" 2002/96/EC.
- The requirements of the European harmonized standards and with the standards specifying the hygiene and safety requirements: EN 12100-1 and 2 - 2004, EN 60204- 1 - 2006, EN 1678 - 1998, EN 60529-2000: IP 55, IP 34.



Head Office, French, Export and Marketing Department:

Tel.: + 33 1 43 98 88 33 - Fax: + 33 1 43 74 36 26
email: international@robot-coupe.com

Robot Coupe Australia: Tel.: (02) 9478 0300 - Fax: (02) 9460 7972

New Zealand: Tel.: 0800 716161 - Fax: 0800 716162
email: orders@robotcoupe.com.au

Robot Coupe U.K. LTD: Tel.: 020 8232 1800 - Fax: 020 8568 4966

2, Fleming Way, Isleworth, Middlesex TW7 6EU - email: sales@robotcoupe.co.uk

Robot Coupe U.S.A.: Tel.: 1-800-824-1646 - Fax: 601-898-9134

email: info@robotcoupeusa.com - website: www.robotcoupeusa.com

www.robot-coupe.com

DISTRIBUTOR :